



Yayasan Perguruan Tinggi Komputer (YPTK) Padang  
**FAKULTAS EKONOMI DAN BISNIS**  
**UNIVERSITAS PUTRA INDONESIA "YPTK"**

Jalan Raya Lubuk Begalung, Padang, Telp. (0751) 776666, 775246 Faks. 71913. Email: admin@upiypk.ac.id Homepage: www.yptk.ac.id

**SURAT TUGAS**

**Nomor: 032/FEB/UPI-YPTK/ST/IV/2019**

Dekan Fakultas Ekonomi dan Bisnis, Universitas Putra Indonesia YPTK Padang dengan ini menugaskan dosen yang tertera di bawah ini:

Nama : **Desi Ilona, SE, MSc, PhD**  
NIP / NIDN : **1001017702**  
Jabatan Fungsional : Lektor (300 Kum)  
Pangkat : Penata/ III/c  
Unit Kerja : **Fakultas Ekonomi dan Bisnis UPI YPTK Padang**

Untuk melaksanakan penelitian dan publikasi yang berjudul Behavioral intention to use accounting application: perceived ease of use as mediating variable.

Demikianlah surat tugas ini dibuat agar dapat dilaksanakan sebagaimana mestinya.

Padang, 15 April 2019  
Dekan

Dekan



**Dr. Elfiswandi, SE, MM, Ak, CA**  
NIDN : 1019046601

Tembusan :

1. Para Dosen Ybs
2. Arsip

---

## About the Journal

[Aims & Scope](#)

[Editorial Team](#)

[Publication Ethics](#)

[Licenses & Copyright Permissions](#)

[Publication and Peer Review Process](#)

[Archiving Policy](#)

[Article Processing Charges](#)

[Complaints & conflict resolution](#)

[Authors Guidelines](#)

Editors Responsibilities

Reviewers Responsibilities

Indexing and Abstracting

## **About JMI**

Aims & Scope

Editorial Team

Publication Ethics

Open Access

Publication and Peer Review Process

Publication Frequency

Archiving Policy

Article Processing Charges

Complaints & conflict resolution

Authors Guidelines

Editors Responsibilities

Reviewers Responsibilities

Indexing and Abstracting

Journal Ownership

[MAKE A SUBMISSION](#)

## **INFORMATION**

---

[For Readers](#)

[For Authors](#)

[For Librarians](#)

## **KEYWORDS**

---

Domestic Tourism Fitness  
Organizational Commitment  
Perceived quality  
Migration  
ARDL Technique  
BMI  
Status  
Innovation  
Assessment Job Satisfaction  
Stock Prices  
Retailing Malaysia Pakistan.  
Inflation  
Education  
Anxiety  
Dividend Policy  
Employee Performance  
Performance impact  
Brand image  
SMEs  
Co-integration  
Firm Performance  
Stress  
Web-retailing  
Behaviour  
Australia  
Banks  
Compensation  
Profitability

## CURRENT ISSUE

---

ATOM 1.0

RSS 2.0

RSS 1.0



## Cited by

---

	All	Since 2016
Citations	550	449
h-index	13	11
i10-index	16	15

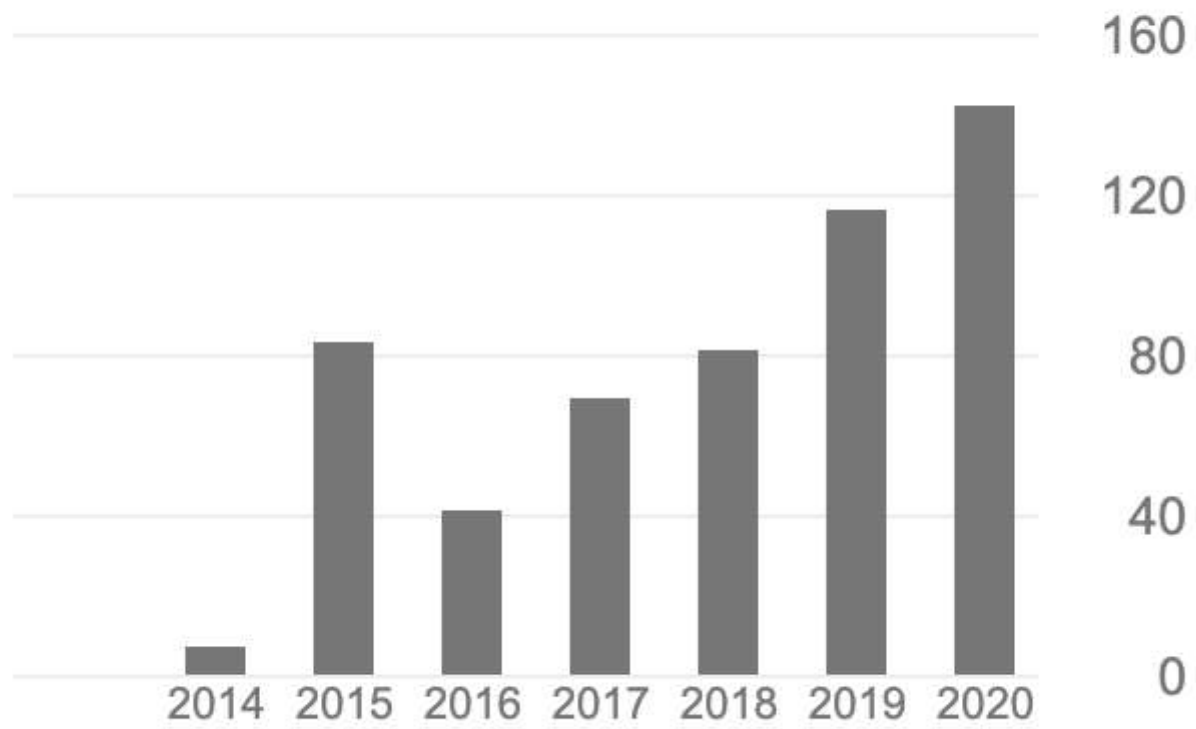







licensed under a [Creative Commons Attribution 4.0 International License](https://creativecommons.org/licenses/by/4.0/).

Head office:

Office # 6, First Floor, A & K Plaza, Near D Watson, F-10 Markaz

Islamabad, PAKISTAN

Email: [info@readersinsight.net](mailto:info@readersinsight.net)

Platform &  
workflow by  
**OJS / PKP**

---

# JOURNAL OF MANAGEMENT INFO

[ABOUT](#) [EDITORIAL TEAM](#) [CURRENT](#) [ARCHIVES](#) [PUBLICATION ETHICS](#) [INDEXING AND ABSTRACTING](#)

[SUBMISSIONS](#) [CONTACT](#)

[HOME](#) / [ARCHIVES](#) / Vol 7 No 4 (2020): December 2020



**PUBLISHED:** 2021-01-17

# ARTICLES

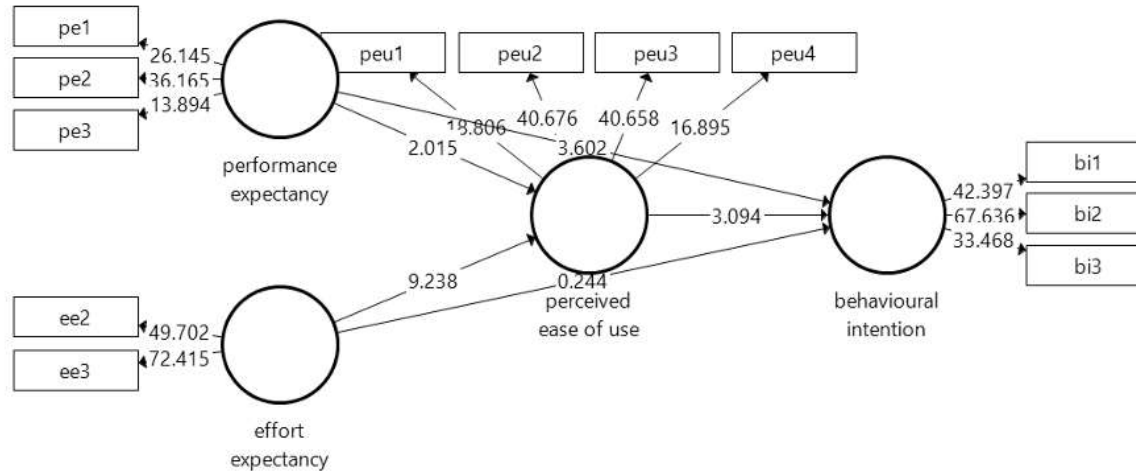

## Behavioural intention to use accounting application: perceived ease of use as mediating variable

Desi Ilona, Zaitul

211-218

PDF



## Impact of training, mood and motivation on employee performance in Universities of Sindh, Pakistan

Amir Ali Khushk

219-231

 PDF

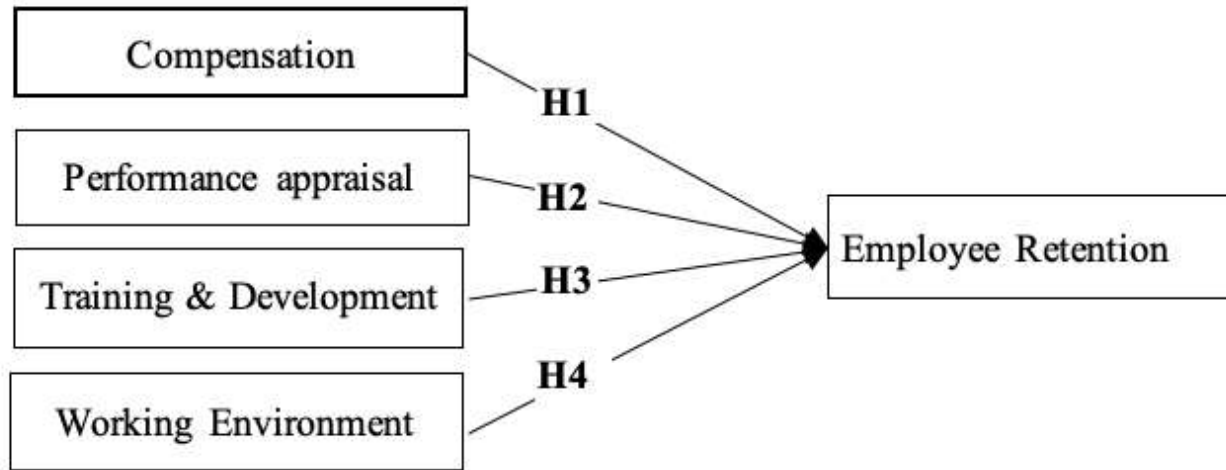

## The role of HRM practices in retaining employees: Evidence from the banking sector

Muhammad Daniyal, Mrestyal Khan

232-247

 PDF

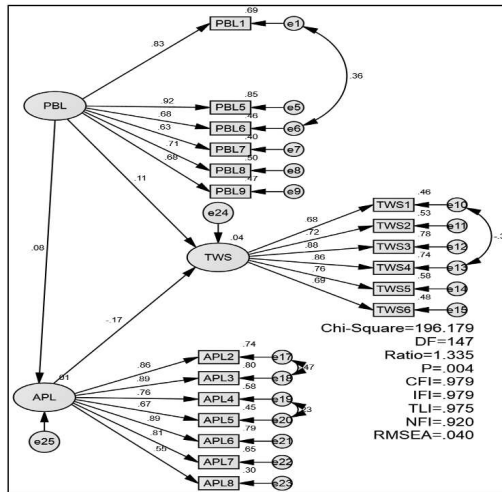

**The mediating impact of assessment process in the relationship between project-based learning and teamwork skills' development**

Shola Francis Bakare , Rotimi Williams Ojulokunrin , Zainab Toyin Jagun, Olowoleru Olaitan Adedeji , Alalade Olugbenga  
248-258

PDF

**A conceptual study on investigating the effect of innovation, transformational leadership and work stressor on employee performance of SMEs in Pakistan**

Jawaria Nasir, Rashidah Mohamad Ibrahim, Muhammad Arslan Sarwar  
259-281

PDF

**About JMI**

Aims & Scope

Editorial Team

Publication Ethics

Open Access

Publication and Peer Review Process

Publication Frequency

Archiving Policy

Article Processing Charges

Complaints & conflict resolution

Authors Guidelines

Editors Responsibilities

Reviewers Responsibilities

Indexing and Abstracting

Journal Ownership

[MAKE A SUBMISSION](#)

## **INFORMATION**

---

For Readers

For Authors

For Librarians

KEYWORDS

---

A word cloud containing the following terms: Remittances, ARDL Technique, Stress Status, Compensation, Job Satisfaction, BMI, Extrinsic Motivation, Small and Medium Enterprises, Intrinsic Motivation, Market Trends, Terrorism, Inflation, Education, Pakistan., Performance, Innovation, Stock Prices, Migration, CSR, Dividend Policy, Fitness, Brand image, COVID-19, Creativity, SMEs, Pakistan, Employee Performance, Malaysia Banks, Assessment, Random Effect, Co-integration, Retailing, and Banks.

## CURRENT ISSUE

---

ATOM 1.0

RSS 2.0

RSS 1.0



## Cited by

---

	All	Since 2016
Citations	550	449
h-index	13	11
...	...	...

---



i10-index

16

15

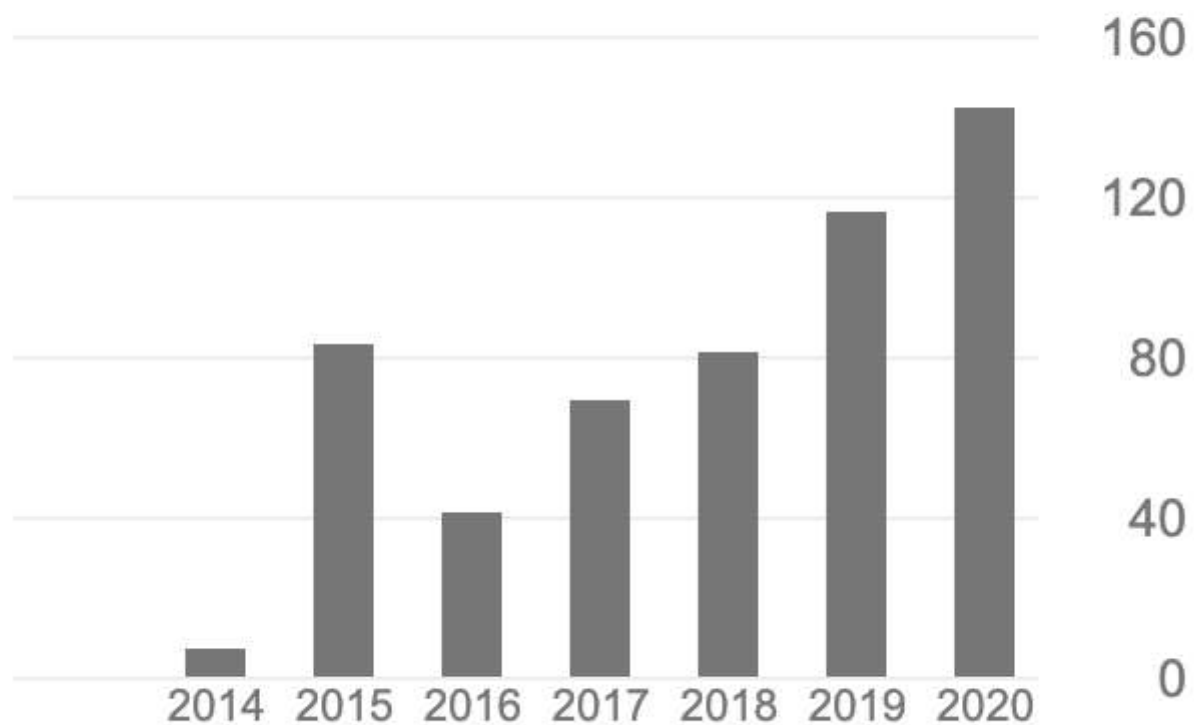





licensed under a [Creative Commons Attribution 4.0 International License](https://creativecommons.org/licenses/by/4.0/).

Head office:

Office # 6, First Floor, A & K Plaza, Near D Watson, F-10 Markaz

Islamabad, PAKISTAN

Email: [info@readersinsight.net](mailto:info@readersinsight.net)

Platform &  
workflow by  
**OJS / PKP**

